

Small hole drilling



Small hole drilling

	Page
H19 (3/4) Integral drill steels	5
H22 (7/8") Integral drill steels	6
Reaming tools	7
H22 Tapered tools, 12° taper	8
H22 Tapered tools, 11° taper.....	9
Stone working tools	10
R22 (7/8") Extension drilling tools	11
R23 (29/32") Extension drilling tools	12
R25 (1") Extension drilling tools	13
Sandvik Alpha. α 250 bit thread	15
R28 (1 1/8") Extension drilling tools	16

Small hole drilling

H19 (3/4) Integral drill steels

Series	Dimensions L			D		Part No.
	mm	ft	in	mm	in	
Shank 19 x 108 mm (3/4"x 4 1/4")						
21	400	1'	4"	29	19/64"	724-0429
	800	2'	7"	28	1 7/64"	724-0828
	1600	5'	3"	27	1 1/16"	724-1627
	2400	7'	10"	26	1 1/32"	724-2426
24	600	2'	-	27	1 1/16"	724-0627
	1200	3'	11"	26	1 1/32"	724-1226
Boulder steel						
	400	1'	4"	24	15/16"	724-0424
	800	2'	7"	23	29/32"	724-0823

Shank 22 x 108 mm (7/8"x 4 1/4")

21	400	1'	4"	24	15/16"	728-0424
	400	1'	4"	29	1 9/64"	728-0429
	800	2'	7"	28	1 7/64"	728-0828
	1600	5'	3"	27	1 1/16"	728-1627

Small hole drilling

H22 (7/8") Integral drill steels

Series	Dimensions L			D		Part No.
	mm	ft	in	mm	in	
Shank 22x108 mm (7/8" x 4 1/4")						
11	800	2'	7"	34	1 11/32"	714-0834-65
	1600	5'	3"	33	1 19/64"	714-1633-65
	2400	7'	10"	32	1 1/4"	714-2432-65
	3200	10'	6"	31	1 7/32"	714-3231
	4000	13'	1"	30	1 3/16"	714-4030
	4800	15'	9"	29	1 9/64"	714-4829
	5600	18'	4"	28	1 7/64"	714-5628-50
	6400	21'	-	27	1 1/16"	714-6427-50
	7200	23'	8"	26	1 1/32"	714-7226-50
	12	800	2'	7"	40	1 37/64"
1600		5'	3"	39	1 17/32"	714-1639-65
2400		7'	10"	38	1 1/2"	714-2438-65
3200		10'	6"	37	1 29/64"	714-3237-65
4000		13'	1"	36	1 27/64"	714-4036-65
4800		15'	9"	35	1 3/8"	714-4835-65
5600		18'	4"	34	1 11/32"	714-5634-65
6400		21'	-	33	1 19/64"	714-6433-65
7200	23'	8"	32	1 1/4"	714-7232-65	
13	400	1'	4"	34	1 11/32"	714-0434-65
	800	2'	7"	33	1 19/64"	714-0833-65
	1200	3'	11"	32	1 1/4"	714-1232-65
	1600	5'	3"	31	1 7/32"	714-1631
	2000	6'	7"	30	1 3/16"	714-2030
16	600	2'	-	35	1 3/8"	714-0635-65
	1200	3'	11"	34	1 11/32"	714-1234-65
	1800	5'	11"	33	1 19/64"	714-1833-65
	2400	7'	10"	32	1 1/4"	714-2432-65
17	600	2'	-	41	1 5/8"	714-0641-65
	1200	3'	11"	40	1 37/64"	714-1240-65
	1800	5'	11"	39	1 17/32"	714-1839-65
	2400	7'	10"	38	1 1/2"	714-2438-65

Shank 22x108 mm (7/8" x 4 1/4")

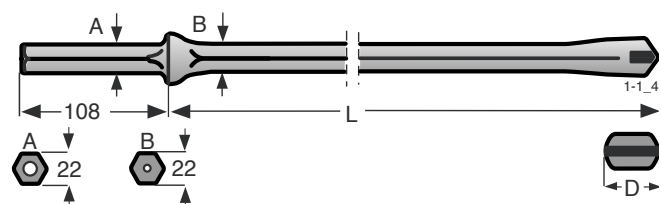

2000	6'	7"	33	1 19/64"	714-2033-65
8000	26'	3"	26	1 1/32"	714-8026-50
8800	28'	11"	25	1"	714-8825-5005
9600	31'	6"	25	1"	714-9625-5005

Shank 22x108 mm (7/8" x 4 1/4")

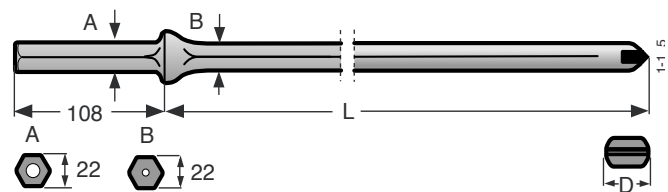

800	2'	7"	29	1 9/64"	714-0829
1600	5'	3"	28	1 7/64"	714-1628-50
2400	7'	10"	27	1 1/16"	714-2427-50

Small hole drilling

Reaming tools



	L			D		Part No.
	mm	ft	in	mm	in	
Pilot rod, Hex 22, 6° taper						
	800	2'	7 1/2"	26	1 1/32"	7922-6108-11
	1200	3'	11 3/4"	26	1 1/32"	7922-6112-11
	1600	5'	3"	26	1 1/32"	7922-6116-11
	2000	6'	6 3/4"	26	1 1/32"	7922-6120-11
	2500	8'	2 1/2"	26	1 1/32"	7922-6124-11

	Buttons, mm		Angle	Dimensions D		Part No.
	Front No Size	Gauge No Size		mm	in	
Reaming bit, 6° taper						
	4x8	8x9	25°	64	2 1/2"	7722-4864-S45
	4x10	8x10	30°	76	3"	7722-4876-S45
	4x10	8x10	30°	89	3 1/2"	7722-4889-S45

Knock-off tool for reaming bit

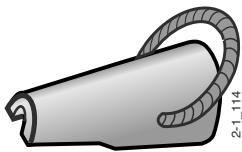

795-1469

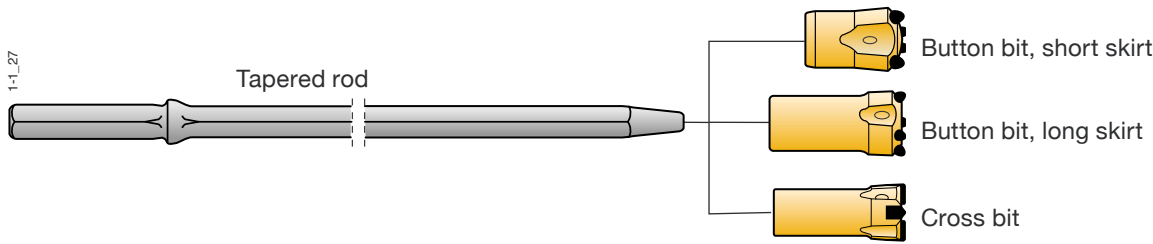

Small hole drilling

H22 Tapered tools, 12° taper

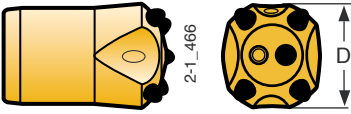
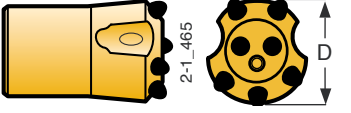

	Flushinghole, mm		Buttons, mm			Dimensions		Part No.
	Front No	Gauge No Size	Front No	Gauge No Size	Angle	D mm	in	
Button bit								
	1x5	1x5	1x7	4x7	35°	28	1 1/8"	7795-6428-B48
	1x5	1x5	1x7	4x7	35°	30	1 3/16"	7795-6430-B48
Button bit								
	2x4	1x4	2x7	5x7	40°	32	1 1/4"	7795-5232-B48
	2x4	1x3,5	2x7	5x8	40°	35	1 3/8"	7795-5235-B48
	2x4	1x4	2x7	5x9	40°	38	1 1/2"	7795-5238-B48
Button bit								
	2x4	1x3.5	2x7	5x7	40°	33	1 9/64"	7770-5233-B48
	2x4	1x3.5	2x7	5x8	40°	35	1 3/8"	7770-5235-B48
Cross bit								
	1x4	2x4	-	-	-	28	1 1/8"	7770-9028-42
	1x4	2x4	-	-	-	30	1 3/16"	7770-9030-42
	1x6	2x4.5	-	-	-	32	1 1/4"	7770-9032-42
	1x6	2x4.5	-	-	-	35	1 3/8"	7770-9035-42

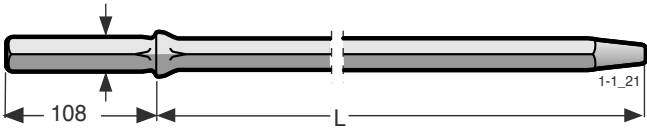
	Dimensions L			D		Part No.
	mm	ft	in	mm	in	
Tapered rod, shank 22x108, carburized						
	610	2'	-	22	7/8"	7870-6106-11
	1220	4'	-	22	7/8"	7870-6112-11
	1830	6'	-	22	7/8"	7870-6118-11
	2000	6'	7"	22	7/8"	7870-6120-11
	2440	8'	-	22	7/8"	7870-6124-11
	3050	10'	-	22	7/8"	7870-6131-11
	3660	12'	-	22	7/8"	7870-6137-11

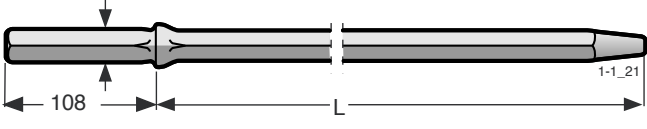
Tapered rod, shank 22x108, HF-hardened - For surface drilling						
	2440	8'	-	22	7/8"	7870-5124-11
	3200	10'	6"	22	7/8"	7870-5132-11
	4000	13'	1 1/2"	22	7/8"	7870-1140-11
	4400	14'	5"	22	7/8"	7870-1144-11
	4800	15'	9"	22	7/8"	7870-1148-11
	5600	18'	4 1/2"	22	7/8"	7870-1156-11
	6400	21'	-	22	7/8"	7870-1164-11
	7200	23'	7 1/2"	22	7/8"	7870-1172-11
	8000	26'	3"	22	7/8"	7870-1180-11
	8800	28'	10 1/2"	22	7/8"	7870-1188-11

Small hole drilling

H22 Tapered tools, 11° taper

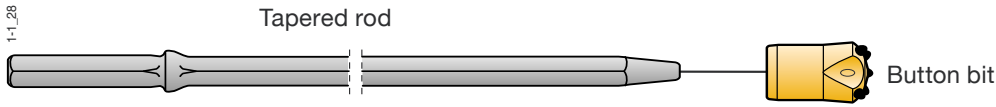

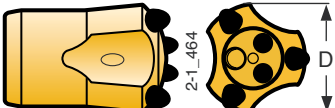
	Flushinghole, mm		Buttons, mm		Angle	Dimensions		Part No.
	Front	Gauge	Front	Gauge		D	in	
Button bit	No Size	No Size	No Size	No Size		mm		
	1x6	2x4	2x7	3x8	35°	32	1 1/4"	7776-1932-B48
	1x6	1x6	1x8	3x9	40°	36	1 7/16"	7776-1936-B48
	1x6	1x6	2x8	3x9	40°	38	1 1/2"	7776-1938-B48
	1x6	1x6	2x8	3x9	40°	40	1 37/64"	7776-1940-B48

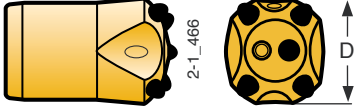
Button bit								
	1x6	1x6	2x8	4x8	40°	38	1 1/2"	7776-6438-B48

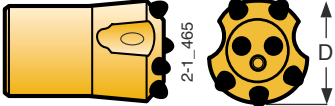
Button bit								
	1x4	1x6	2x7	5x7	40°	32	1 1/4"	7776-4432-B48
	1x5	1x5	2x7	5x7	35°	35	1 3/8"	7776-4435-B48
	1x6	1x5	2x7	5x8	35°	38	1 1/2"	7776-4438-B48
	1x6	1x5	2x8	5x9	35°	40	1 37/64"	7776-4440-B48

	Dimensions			D		Part No.
	L	ft	in	mm	in	
Tapered rod, shank 22x108, carburized						
	610	2'	-	22	7/8"	7876-6106-11
	800	2'	7 1/2"	22	7/8"	7876-6108-11
	1220	4'	-	22	7/8"	7876-6112-11
	1830	6'	-	22	7/8"	7876-6118-11
	2000	6'	7"	22	7/8"	7876-6120-11
	2440	8'	-	22	7/8"	7876-6124-11
	3050	10'	-	22	7/8"	7876-6131-11
	3600	11'	9 1/2"	22	7/8"	7876-6136-11

Small hole drilling

Stone working tools

Plug hole integral steel

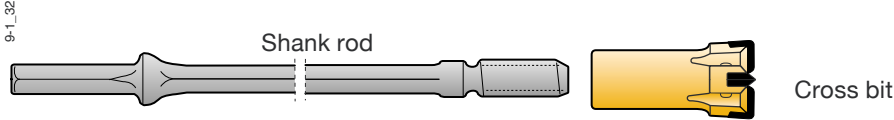

	Dimensions			D		Part No.
	L			mm	in	
Plug hole integral steel						
	150		6"	17	21/32"	721-1517
	160		6 1/4"	20	25/32"	721-1620
	200		7 7/8"	20	25/32"	721-2020
	240		9 29/64"	20	25/32"	721-2420
	280		11 1/32"	20	25/32"	721-2820
	310		11 1/4"	20	25/32"	721-3120
	160		6 1/4"	22	7/8"	721-1622
	190		7 1/2"	22	7/8"	721-1922

Shank rod, Hex22 - R25

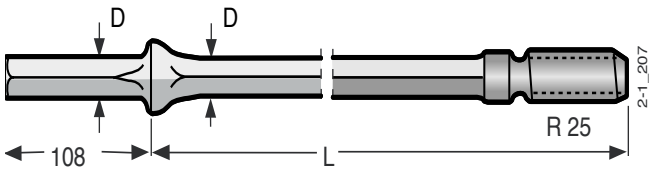

255		10 3/64"	22	7/8"	7802-6103-13
800	2'	2 1/2"	22	7/8"	7802-6108-13
1000	3'	3"	22	7/8"	7802-6110-13

Cross bit, R25

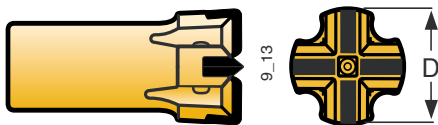

381 1/2"	7732-1438-42
411 5/8"	7732-1441-42
451 3/4"	7732-1045-42

Small hole drilling

R22 (7/8") Extension drilling tools

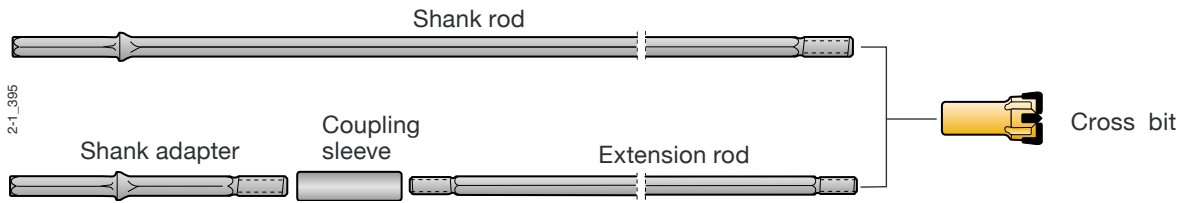

Flushing hole, mm		Gauge		D		Bit classification	Part No.
Front	No Size	No	Size	mm	in		

Cross bit



1	4.5	2	4.5	38	1 1/2"	-	7731-1038-42
---	-----	---	-----	----	--------	---	--------------

Dimensions			D		Part No.
L	ft	in	mm	in	

Extension rod R22 - Hex 22 - R22

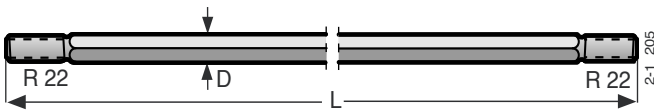

800	2'	7"	22	7/8"	7851-1308-20
1200	3'	11"	22	7/8"	7851-1312-20
1600	5'	3"	22	7/8"	7851-1316-20

Coupling sleeve, R22

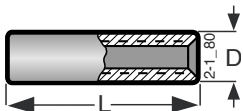

140	-	5 1/2"	31	1 7/32"	7991-2031
-----	---	--------	----	---------	-----------

Shank adapter/Shank rod, Hex 22 - R22

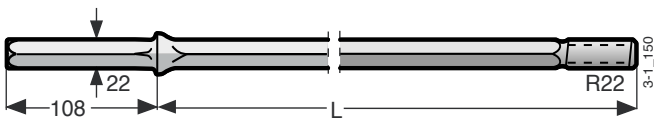

255	-	10 3/64"	22	7/8"	7801-6103-13
1000	3'	3"	22	7/8"	7801-6110-13

Small hole drilling

R23 (29/32") Extension drilling tools

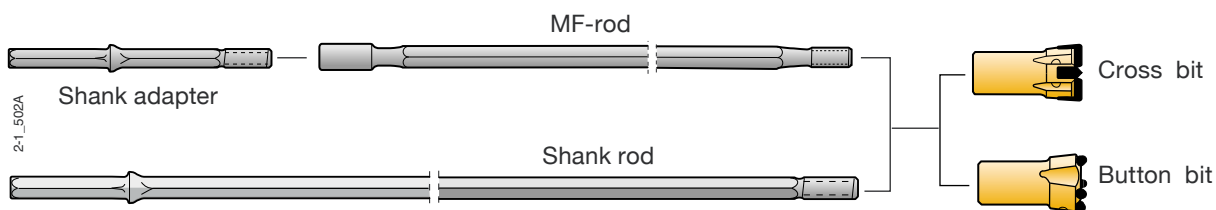

	Flushinghole, mm		Buttons, mm		Angle	Dimensions		Bit classification	Part No.
	Front No	Gauge Size	Front No	Gauge Size		D mm	in		

Button bit

	1	5.0	1	6	2x7	5x8	40°	35	1 3/8"	HMCA	7737-5235-R48
	1	6.0	1	6	2x7	5x8	35°	38	1 1/2"	HMCA	7737-4438A-B48
	1	5.0	1	6	2x8	5x9	35°	41	1 5/8"	HMCA	7737-5241-R48
	3	5.0	-	-	3x8	6x9	30°	45	1 3/4"	HMCA	7737-5345-R48

Cross bit, Extra Heavy Duty

	1	4.5	2	4.5	-	-	-	33	1 5/16"	-	7737-1633-11
--	---	-----	---	-----	---	---	---	----	---------	---	--------------

Cross bit, Heavy Duty

	1	4.5	2	4.5	-	-	-	35	1 3/8"	-	7737-1435-42
	1	4.5	2	4.5	-	-	-	38	1 1/2"	-	7737-1438-42

MF-rod, R23 - Hex 22 - R23

	2095	6'	10 1/2"	22	7/8"	7857-4821-20
	3050	10'	-	22	7/8"	7857-4831-20

Female end OD 31 mm.

Shank adapter / Shank rod, Hex 22 - R23

	255	-	10 3/64"	22	7/8"	7807-6103-11
	2400	8'	-	22	7/8"	7807-6124-11
	3200	10'	-	22	7/8"	7807-6132-11
	3600	11'	9 5/8"	22	7/8"	7807-6136-11





Shank rod, Hex 25 - R23

	255	-	10 3/64"	25	1"	7807-7103-11
	3600	11'	9"	25	1"	7807-7136-11

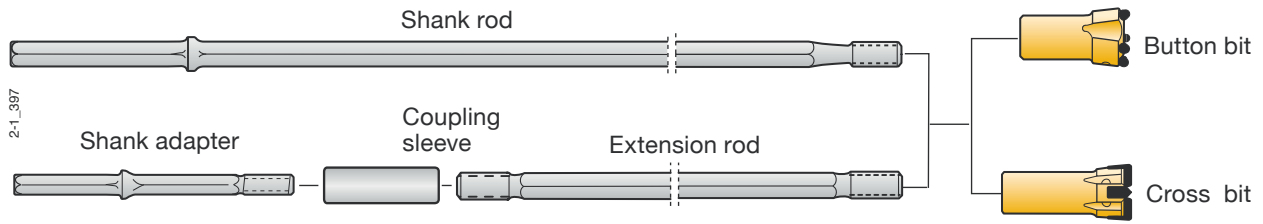
Small hole drilling

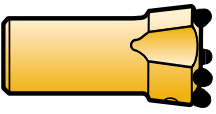
R25 (1") Extension drilling tools

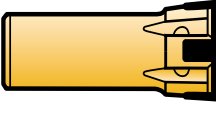

	Flushinghole, mm		Buttons, mm			Dimensions		Bit classification	Part No.	
	Front No	Gauge Size	Front No	Gauge Size	Angle	D mm	in			
Button bit										
	1)	1x5	1x6	2x7	5x8	35°	35	1 3/8"	HMCA	7732-5235-S48
	1)	1x5	1x6	2x7	5x9	30°	38	1 1/2"	HMCA	7732-5238-S48
		1x5	1x6	2x7	5x9	35°	38	1 1/2"	HMCA	7732-5238-R48
		1x5	1x6	2x8	5x9	35°	41	1 5/8"	HMCA	7732-5241-S48
		3x4.5	-	3x8	6x9	40°	45	1 3/4"	MSCFAN	7732-5345F-R48
Cross bit, Heavy Duty										
	1)	1x5	2x5	-	-	-	35	1 3/8"	-	7732-1435-42
	1)	1x5	2x5	-	-	-	38	1 1/2"	-	7732-1438-42
		1x5	2x5	-	-	-	41	1 5/8"	-	7732-1441-42
Cross bit										
		1x5	2x5	-	-	-	45	1 3/4"	-	7732-1045-42
		1x5	2x5	-	-	-	51	2"	-	7732-1051-42

Shank adapter / rod, Hex 22 x R25	Dimensions		D mm	D in	Part No.
	L mm	L ft			
	255	-	22	7/8"	7802-6103-13
	800	2'	22	7/8"	7802-6108-13
	1000	3'	22	7/8"	7802-6110-13

1) For one-rod drilling.

Small hole drilling

R25 (1") Extension drilling tools

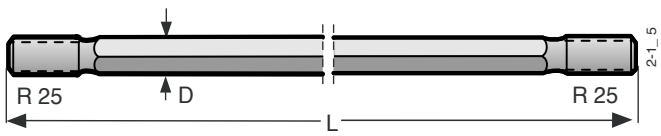
	Dimensions			D		Part No.
	L			mm	in	
	mm	ft	in			
Extension rod, R25 - Hex 25 - R25						
	915	3'	-	25	1"	7852-2309-20
	1220	4'	-	25	1"	7852-2312-20
	1525	5'	-	25	1"	7852-2315-20
	1830	6'	-	25	1"	7852-2318-20
	2435	8'	-	25	1"	7852-2324-20
	3050	10'	-	25	1"	7852-2331-20

Coupling sleeve, R25

	160	-	6 1/4"	35	1 3/8"	7992-2035
--	-----	---	--------	----	--------	-----------

Small hole drilling

Sandvik Alpha. α 250 bit thread



Shank rod

Button bit

Flushinghole, mm		Buttons, mm		Dimensions D	Bit classi- fication	Part No.
Front	Gauge	Front	Gauge			
No Size	No Size	No Size	No Size	Angle		

Button bit

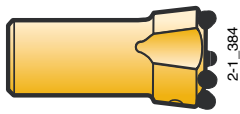

1x5	1x6	2x7	5x8	40°	35	1 3/8"	HMCA	7764-5235-R48
1x5	1x6	2x7	5x9	35°	38	1 1/2"	HMCA	7764-5238-R48

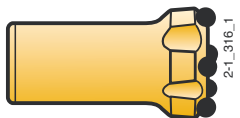

3x4.5	-	3x8	6x9	40°	45	1 3/4"	MSCFAN	7764-5345F-R48
-------	---	-----	-----	-----	----	--------	--------	----------------

Dimensions

L			D		Part No.
mm	ft	in	mm	in	

Shank rod, Hex 25 - α 250

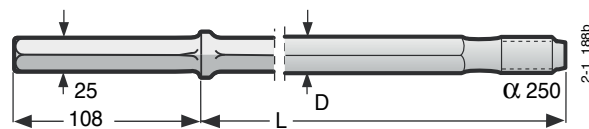

3600	11'	9 5/8 "	25	1"	7814-7136-11
------	-----	---------	----	----	--------------

Small hole drilling

R28 (1 1/8") Extension drilling tools

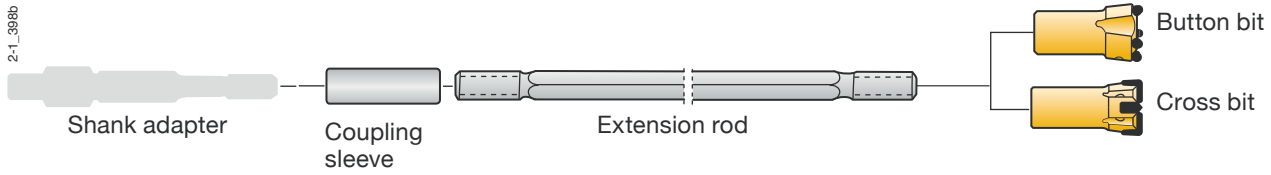

	Flushinghole, mm		Buttons, mm			Dimensions		Bit classification	Part No.
	Front No	Gauge Size	Front No	Gauge Size	Angle	D mm	in		

Button bit, CAPP 52



1)	1x5	1x6	2x7	5x9	35°	38	1 1/2"	MSCFAN	7739-5238-R48
1)	1x5	1x6	2x7	5x9	30°	38	1 1/2"	HMCA	7739-5238-S48
1)	1x5	1x6	2x8	5x9	35°	41	1 5/8"	HMCA	7739-5241-S48
	1x5	1x6	2x8	5x10	35°	43	1 11/16"	HMCA	7739-5243-S48

Cross bit, Heavy Duty



1)	1x5	2x5	-	-	-	38	1 1/2"	-	7739-1438-42
1)	1x5	2x5	-	-	-	41	1 5/8"	-	7739-1441-42

Extension rod, R28 - Hex 28 - R28



	Dimensions L			D		Part No.
	mm	ft	in	mm	in	
	3050	10'	-	28	1 1/8"	7859-2931-20

Coupling sleeve, R28

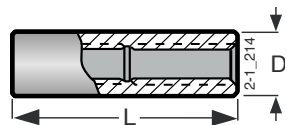

	150	-	5 29/32"	40	1 37/64"	7999-3640
--	-----	---	----------	----	----------	-----------

1) For one-rod drilling.